



UNIT IV

ACOUSTICS AND ULTRASONIC

BY

BHANUDAS NARWADE

DEGLOOR COLLEGE, DEGLOOR



ULTRASONICS:

- **Introduction to Ultrasonics**
- **Properties of Ultrasonic waves**
- **Ultrasonic Production- Magnetostriction Method**
- **Ultrasonic Production- Piezo Electric Method**
- **Applications of Ultrasonics**



Introduction to Ultrasonics

- The word ***ultrasonic*** combines the Latin roots *ultra*, meaning '***beyond***' and *sonic*, or ***sound***.
- The sound waves having frequencies above the audible range i.e. above 20000Hz are called ***ultrasonic waves***.
- Generally these waves are called as ***high frequency waves***.
- The field of ultrasonics have applications for imaging, detection and navigation.
- The broad sectors of society that regularly apply ultrasonic technology are the medical community, industry, the military and private citizens.



Properties of ultrasonic waves

- (1) They have a high energy content.
- (2) Just like ordinary sound waves, ultrasonic waves get reflected, refracted and absorbed.
- (3) They can be transmitted over large distances with no appreciable loss of energy.
- (4) If an arrangement is made to form stationary waves of ultrasonics in a liquid, it serves as a diffraction grating. It is called an **acoustic grating**.
- (5) They produce intense heating effect when passed through a substance.



Ultrasonics Production

Ultrasonic waves are produced by the following methods.

- (1) Magnetostriction generator or oscillator
- (2) Piezo-electric generator or oscillator



Magnetoagnetostriction Generator

Principle: Magnetostriction effect

When a ferromagnetic rod like iron or nickel is placed in a magnetic field parallel to its length, the rod experiences a small change in its length. This is called magnetostriction effect.

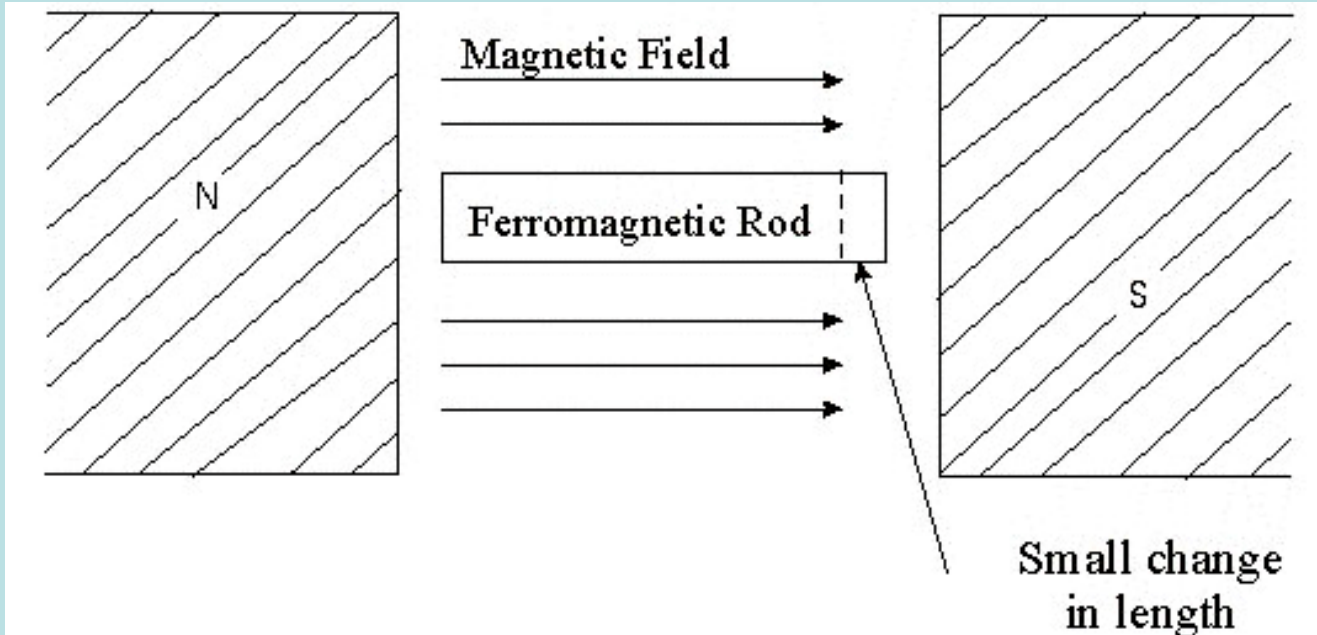

The change in length (increase or decrease) produced in the rod depends upon the strength of the magnetic field, the nature of the materials and is independent of the direction of the magnetic field applied.



Construction

The experimental arrangement is shown in Figure

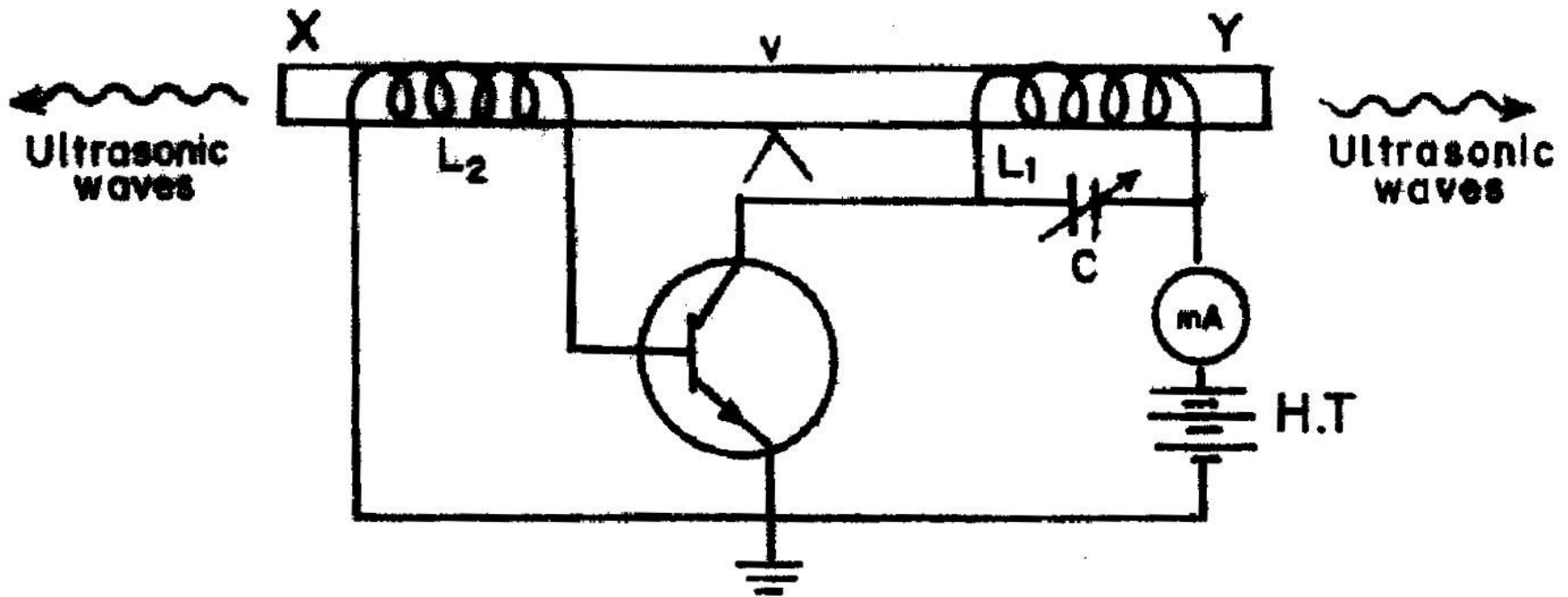

Magnetostriction oscillator



- XY is a rod of ferromagnetic materials like iron or nickel. The rod is clamped in the middle.
- The alternating magnetic field is generated by electronic oscillator.
- The coil L_1 wound on the right hand portion of the rod along with a variable capacitor C .
- This forms the *resonant circuit* of the collector tuned oscillator. The frequency of oscillator is controlled by the variable capacitor.
- The coil L_2 wound on the left hand portion of the rod is connected to the base circuit. The coil L_2 acts as *feed – back loop*.



Working

- When High Tension (H.T) battery is switched on, the collector circuit oscillates with a frequency,

$$f = \frac{1}{2 \pi \sqrt{L_1 C}}$$

- This alternating current flowing through the coil L_1 produces an alternating magnetic field along the length of the rod. The result is that the rod starts vibrating due to magnetostrictive effect.



The frequency of vibration of the rod is given by

$$n = \frac{1}{2l} \sqrt{\frac{Y}{\rho}}$$

where l = length of the rod

Y = Young's modulus of the rod material and

ρ = density of rod material

- The capacitor C is adjusted so that the frequency of the oscillatory circuit is equal to natural frequency of the rod and thus resonance takes place.
- Now the rod vibrates longitudinally with maximum amplitude and generates ultrasonic waves of high frequency from its ends.



Advantages

1. The design of this oscillator is very simple and its production cost is low
2. At low ultrasonic frequencies, the large power output can be produced without the risk of damage of the oscillatory circuit.

Disadvantages

1. It has low upper frequency limit and cannot generate ultrasonic frequency above 3000 kHz (ie. 3MHz).
2. The frequency of oscillations depends on temperature.
3. There will be losses of energy due to hysteresis and eddy current.



Piezo Electric Generator or Oscillator

Principle : Inverse piezo electric effect

- If mechanical pressure is applied to one pair of opposite faces of certain crystals like quartz, equal and opposite electrical charges appear across its other faces. This is called as piezo-electric effect.
- The converse of piezo electric effect is also true.
- If an electric field is applied to one pair of faces, the corresponding changes in the dimensions of the other pair of faces of the crystal are produced. This is known as ***inverse piezo electric*** effect or ***electrostriction***.



Construction

The circuit diagram is shown in Figure

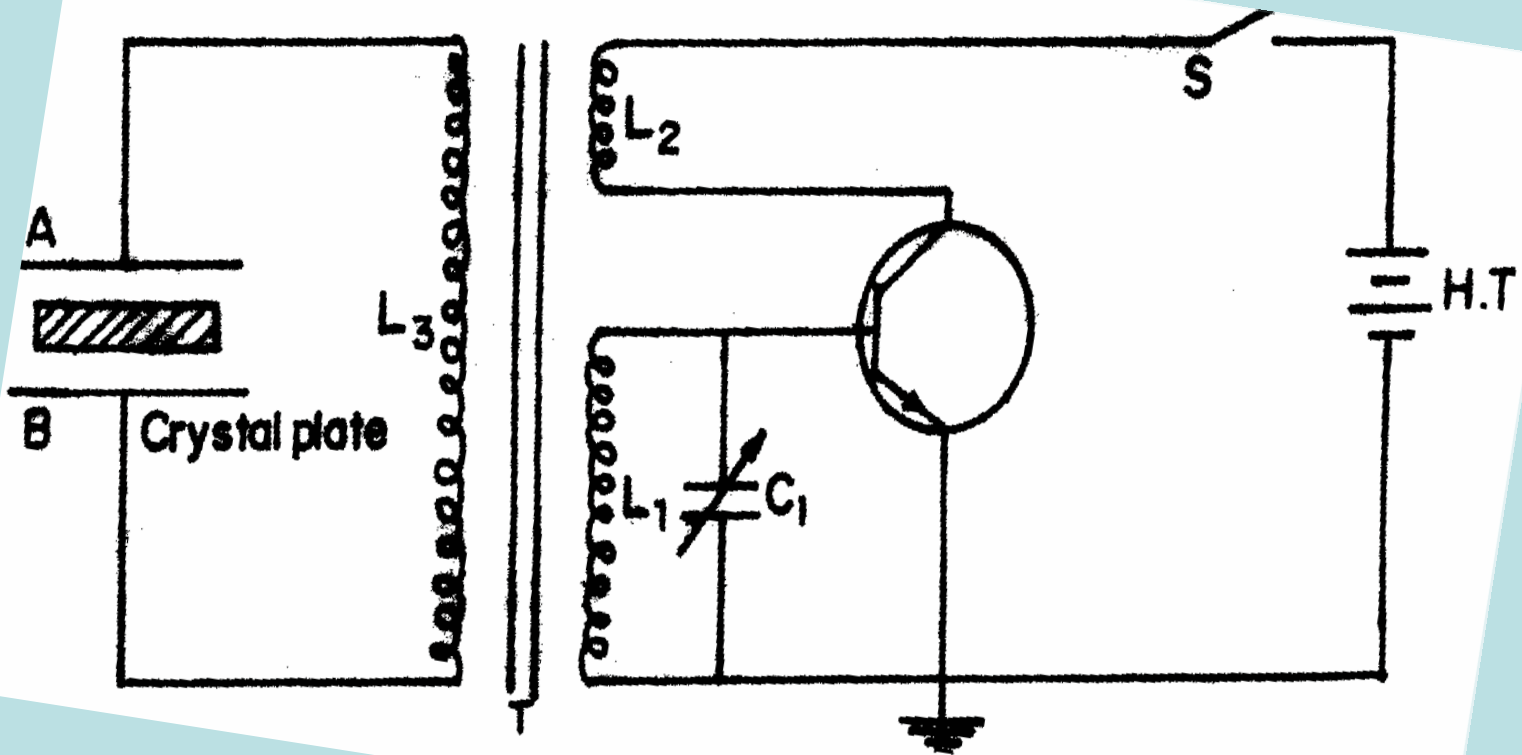

Piezo electric oscillator



- The quartz crystal is placed between two metal plates A and B.
- The plates are connected to the primary (L_3) of a transformer which is inductively coupled to the electronics oscillator.
- The electronic oscillator circuit is a base tuned oscillator circuit.
- The coils L_1 and L_2 of oscillator circuit are taken from the secondary of a transformer T.
- The collector coil L_2 is inductively coupled to base coil L_1 .
- The coil L_1 and variable capacitor C_1 form the *tank circuit* of the oscillator.



Working

- When H.T. battery is switched on, the oscillator produces high frequency alternating voltages with a frequency.

$$f = \frac{1}{2\pi\sqrt{L_1 C_1}}$$

- Due to the transformer action, an oscillatory e.m.f. is induced in the coil L_3 . This high frequency alternating voltages are fed on the plates A and B.
- Inverse piezo-electric effect takes place and the crystal contracts and expands alternatively. The crystal is set into mechanical vibrations.
- The frequency of the vibration is given by

$$n = \frac{P}{2l} \sqrt{\frac{Y}{\rho}}$$

where $P = 1, 2, 3, 4 \dots$ etc. for fundamental, first over tone, second over tone etc.,
 $Y =$ Young's modulus of the crystal and
 $\rho =$ density of the crystal.



- The variable condenser C_1 is adjusted such that the frequency of the applied AC voltage is equal to the natural frequency of the quartz crystal, and thus resonance takes place.
- The vibrating crystal produces longitudinal ultrasonic waves of large amplitude.



Advantages

- Ultrasonic frequencies as high as 5×10^8 Hz or 500 MHz can be obtained with this arrangement.
- The output of this oscillator is very high.
- It is not affected by temperature and humidity.

Disadvantages

- The cost of piezo electric quartz is very high
- The cutting and shaping of quartz crystal are very complex.



Applications of Ultrasonic Waves in Engineering

(1) Detection of flaws in metals (Non Destructive Testing –NDT)

Principle

- Ultrasonic waves are used to detect the presence of flaws or defects in the form of cracks, blowholes porosity etc., in the internal structure of a material
- By sending out ultrasonic beam and by measuring the time interval of the reflected beam, flaws in the metal block can be determined.



Experimental setup

It consists of an ultrasonic frequency generator and a cathode ray oscilloscope (CRO), transmitting transducer(A), receiving transducer(B) and an amplifier.

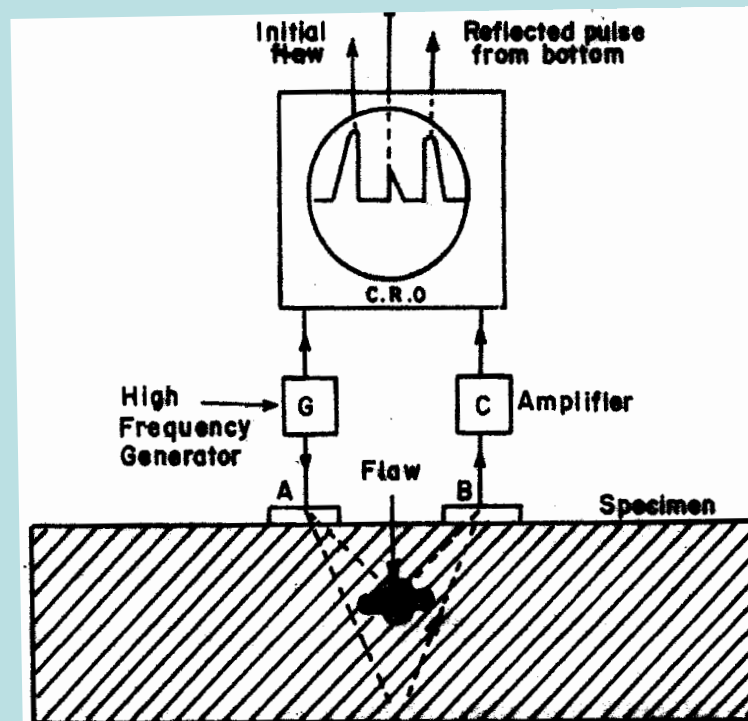



Working

- In flaws, there is a change of medium and this produces reflection of ultrasonic at the cavities or cracks.
- The reflected beam (echoes) is recorded by using cathode ray oscilloscope.
- The time interval between initial and flaw echoes depends on the range of flaw.
- By examining echoes on CRO, flaws can be detected and their sizes can be estimated.



Features

- This method is used to detect flaws in all common structural metals and other materials like rubber tyres etc.
- The method is very cheap and of high speed of operation.
- It is more accurate than radiography.



(2) Ultrasonic Drilling

- Ultrasonics are used for making holes in very hard materials like glass, diamond etc.
- For this purpose, a suitable drilling tool bit is fixed at the end of a powerful ultrasonic generator.
- Some slurry (a thin paste of carborundum powder and water) is made to flow between the bit and the plate in which the hole is to be made
- Ultrasonic generator causes the tool bit to move up and down very quickly and the slurry particles below the bit just remove some material from the plate.
- This process continues and a hole is drilled in the plate.

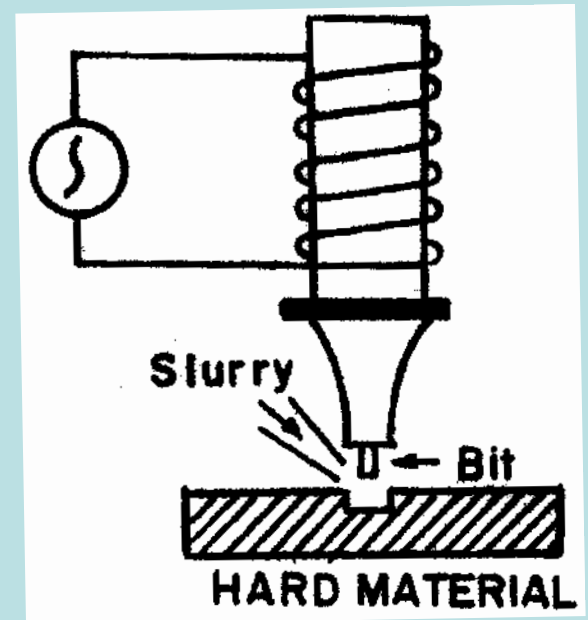



(3) Ultrasonic welding

- The properties of some metals change on heating and therefore, such metals cannot be welded by electric or gas welding.
- In such cases, the metallic sheets are welded together at room temperature by using ultrasonic waves.
- For this purpose, a hammer H is attached to a powerful ultrasonic generator as shown in Figure

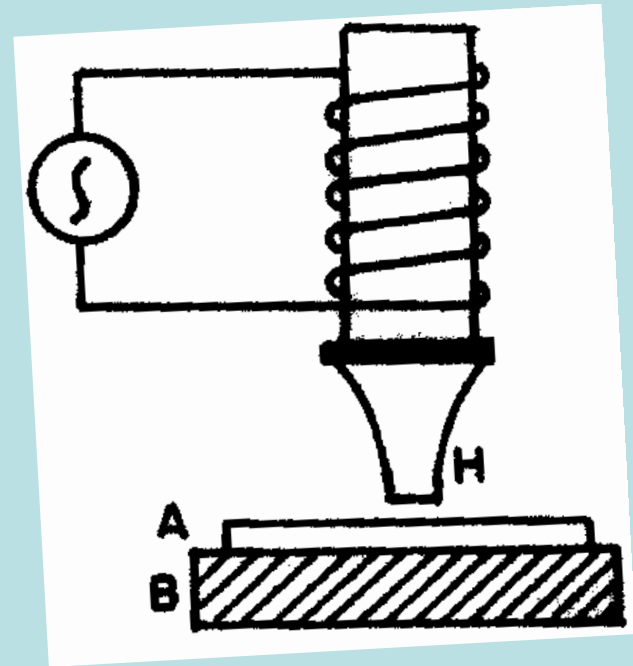



- The metallic sheets to be welded are put together under the tip of hammer H.
- The hammer is made to vibrate ultrasonically. As a result, it presses the two metal sheets very rapidly and the molecules of one metal diffuse into the molecules of the other.
- Thus, the two sheets get welded without heating. This process is known as ***cold welding***.



(4) Ultrasonic soldering

- Metals like aluminium cannot be directly soldered. However, it is possible to solder such metals by ultrasonic waves.
- An ultrasonic soldering iron consists of an ultrasonic generator having a tip fixed at its end which can be heated by an electrical heating element.
- The tip of the soldering iron melts solder on the aluminium and the ultrasonic vibrator removes the aluminium oxide layer.
- The solder thus gets fastened to clear metal without any difficulty.



(5) Ultrasonic cutting and machining

Ultrasonic waves are used for cutting and machining.

(6) Ultrasonic cleaning

It is the most cheap technique employed for cleaning various parts of the machine, electronic assemblies, armatures, watches etc., which cannot be easily cleaned by other methods.



(7) SONAR

- SONAR is a technique which stands for ***Sound Navigation and Ranging***.
- It uses ultrasonics for the detection and identification of under water objects.
- The method consists of sending a powerful beam of ultrasonics in the suspected direction in water.
- By noting the time interval between the emission and receipt of beam after reflection, the distance of the object can be easily calculated.
- The change in frequency of the echo signal due to the Doppler effect helps to determine the velocity of the body and its direction.



- Measuring the time interval (t) between the transmitted pulses and the received pulse, the distance $d = \frac{vt}{2}$ between the transmitter and the remote object is determined using the formula., where v is the velocity of sound in sea water.
- The same principle is used to find the depth of the sea.

Applications of SONAR

1. Sonar is used in the location of shipwrecks and submarines on the bottom of the sea.
2. It is used for fish-finding application .
3. It is used for seismic survey.



Applications of Ultrasonics in Medicine

(1) Diagnostic sonography

- Medical sonography (ultrasonography) is an ultrasound-based diagnostic medical imaging technique used to visualize muscles, tendons, and many internal organs, their size, structure and any pathological lesions.
- They are also used to visualize the foetus during routine and emergency prenatal care. Ultrasound scans are performed by medical health care professionals called sonographers. Obstetric sonography is commonly used during pregnancy.



Obstetric ultrasound is primarily used to:

- Date the pregnancy
- Check the location of the placenta
- Check for the number of fetuses
- Check for physical abnormalities
- Check the sex of the baby
- Check for fetal movement, breathing, and heartbeat.



(2) Ultrasound therapeutic applications

- Treating malignant tumors and other disorders, via a process known as Focused Ultrasound Surgery (FUS) or HIFU, High Intensity Focused Ultrasound.

These procedures generally use lower frequencies than medical diagnostic ultrasound (from 250kHz to 2000kHz), but significantly higher time-averaged intensities.



- More power ultrasound sources may be used to clean teeth in dental hygiene or generate local heating in biological tissue, e.g. in occupational therapy, physical therapy and cancer treatment.
- ***Extracorporeal shock wave lithotripsy*** uses a powerful focused ultrasound source to break up kidney stones.
- Focused ultrasound sources may be used for ***cataract*** treatment by phacoemulsification.



- Doppler ultrasound is being tested for use in aiding tissue plasminogen activator treatment in stroke sufferers. This procedure is called ***Ultrasound-Enhanced Systemic Thrombolysis***.
- Ultrasound has been shown to act synergistically with antibiotics in bacterial cell killing.



(3) Ultrasonic blood Flow meter

Ultrasonic waves are used for studying the blood flow by measuring the change in their frequency produced due to ***Doppler's effect***.

Note : Physiological effects of ultrasound energy

Ultrasound energy has two physiological effects :

1. Enhance inflammatory response
2. Heats soft tissue.



- Ultrasound energy produces a mechanical pressure wave through soft tissue
- This pressure wave causes microscopic bubbles in living tissues, and distortion of the cell membrane, influencing ion fluxes and intracellular activity. When ultrasound enters the body, it causes molecular friction and heats the tissues slightly.
- In some cases, it can also cause small pockets of gas in body fluids or tissues to expand and contract / collapse (***cavitations***).
- The long-term effects of tissue heating and cavitations are not known.



Some Other Applications of Ultrasonics

(1) Ultrasonic guidance for the blind

- Ultrasonic waves are used for guiding the blind who carries a walking stick containing an ultrasonic transmitter and receiver.
- Ultrasonic signals reflected from any obstacles are fed to the head phones through a suitable electronic circuit which enables the blind person to detect and estimate the distance of the obstacle.



(2)Ultrasound in research

- Scientists often use in research, for instant to break up high molecular weight polymers, thus creating new plastic materials.
- Indeed, ultrasound also makes it possible to determine the molecular weight of liquid polymers, and to conduct other forms of investigation on the physical properties of materials.
- Ultrasonic can also speed up certain chemical reactions. Hence it has gained application in agriculture, that seeds subjected to ultrasound may germinate more rapidly and produce higher yields.



Worked Problem

- A quartz crystal of thickness 1 mm is vibrating at resonance. Calculate the fundamental frequency. Given Y for quartz = $7.9 \times 10^{10} \text{ Nm}^{-2}$ and ρ for quartz = 2650 kg m^{-3} .**

The frequency of the vibration

$$f = \frac{P}{2t} \sqrt{\frac{Y}{\rho}}$$



Here $P = 1$

$$f = \frac{1}{2 \times 0.001} \sqrt{\frac{7.9 \times 10^{10}}{2650}}$$
$$= 2.72998 \times 10^6 \text{ Hz}$$

The fundamental frequency of the quartz crystal

$$= 2.730 \times 10^6 \text{ Hz} = \mathbf{2.73\text{MHz}}$$



THANK YOU





Properties of ultrasonic waves

- (1) They have a high energy content.
- (2) Just like ordinary sound waves, ultrasonic waves get reflected, refracted and absorbed.
- (3) They can be transmitted over large distances with no appreciable loss of energy.
- (4) If an arrangement is made to form stationary waves of ultrasonics in a liquid, it serves as a diffraction grating. It is called an **acoustic grating**.
- (5) They produce intense heating effect when passed through a substance.